

This page was last updated on \$Date: 1998/07/25 17:05:50 \$

Click here to go to my [Patents](#) web-site.

PRELIMINARY PATENT DESCRIPTION "BATTERY" Docket Number 1687

T. Townsend Brown

DESCRIPTION:

This invention relates, in general, to a new and unique method for generating electricity. In particular, it relates to a type of battery which, unlike other batteries, is not powered by chemical action. While it functions as an electromotance, it is not its own (self-contained) source of energy. While the physical principles underlying this invention are not clearly understood, it is presently believed, supported by other evidence, that the energy source is extraterrestrial, coming to the Earth from cosmic space in the form of penetrating gravitational radiation. It is believed that this gravitic radiation coming from cosmological sources is of ultra-high frequency, extending possibly into the angstrom range.

Strictly speaking, while this invention may be classified for patent purposes as a new form of "battery" - it could more accurately be termed an "energy converter" or a gravitovoltic device. From the practical operational standpoint, however, it is appropriately referred to as a battery.

The active ingredient of the subject battery is a massive high-K dielectric material, such as heavy metal oxides or carbides. For the sake of clarity in this patent application, tungsten carbide (specific gravity 17.0) is selected as one of the best, if not the best, active ingredient to use. Heavy metal oxides such as lead monoxide (litharge), osmium or barium compounds or the like may be used with similar results. The electrical output is conducted from the said active (receptor) mass by suitably placed electrodes. This output is observed in the form of a DC self-potential.

SPECIFICATIONS:

[Figure 1](#) is a perspective of the said battery, showing insulated enclosure *1* containing a volume of heavy powder *2* such as tungsten carbide with a binding agent, together with electrodes *3* and *4* attached thereto and leads *5* and *6* to conduct the generated current to external load *7*.

[Figure 2](#) is a circuit diagram of [Figure 1](#) showing additionally the means to polarize the battery initially. Polarization voltage is supplied by high voltage source *8*. Voltage is supplied only while the mixture is cooling and/or hardening. This circuit is then disconnected.

It is necessary, initially, to polarize the battery in order to orient the dipole molecules and align the particles of powder so that output EMF is additive. This alignment of dipoles or polarization, induced while the active material is fluid, is retained and persists after the active material cools or hardens.

The battery is constructed in the following steps:

1. Tungsten carbide powder is mixed with molten carnauba wax or other suitable binder and the heavy mixture poured into insulated container *1* and allowed to cool or harden.
2. During cooling, a high voltage is placed across electrodes *3* and *4* as shown in [Figure 2](#), so as to electrically polarize the mixture. This polarization is necessary so as to permit subsequent energy (gravitovoltic) conversion from the incident radiation.
3. Following polarization, cooling and solidification, the battery is ready to operate and will continue thereafter to generate self-potential with integrated power far in excess of the power required for polarization. It is observed in tests extending over many years that, whereas the output undergoes diurnal and secular variations, it does not permanently diminish or disappear. In other words, the evidence to date is that this form of battery has no fixed life, as other (chemical) batteries, but continues to generate electricity indefinitely.

While I have in the foregoing specifications referred to tungsten carbide and carnauba wax as preferred ingredients, it is to be clearly understood that other massive high-K dielectrics and plastic (or other) binders may be utilized without departing from the spirit of the invention as intended to be covered in the hereto appended claims.

CLAIMS:

1. Method of generating electricity consisting in utilizing a mass of tungsten carbide powder, binding said powder in a suitable semi-conductor, polarizing said mass by applying high voltage thereto while said binder is hardening and utilizing collector electrodes and leads attached thereto to conduct away the generated electricity.
2. Method of generating electricity comprising mixing powdered tungsten carbide with molten carnauba wax, allowing said mixture to harden within an intense electrical field, removing said field and utilizing the perpetual self-potential of said mixture

to energize an external load.

Inventor

T. Townsend Brown

Sunnyvale, California

April 28, 1976

Figure 1

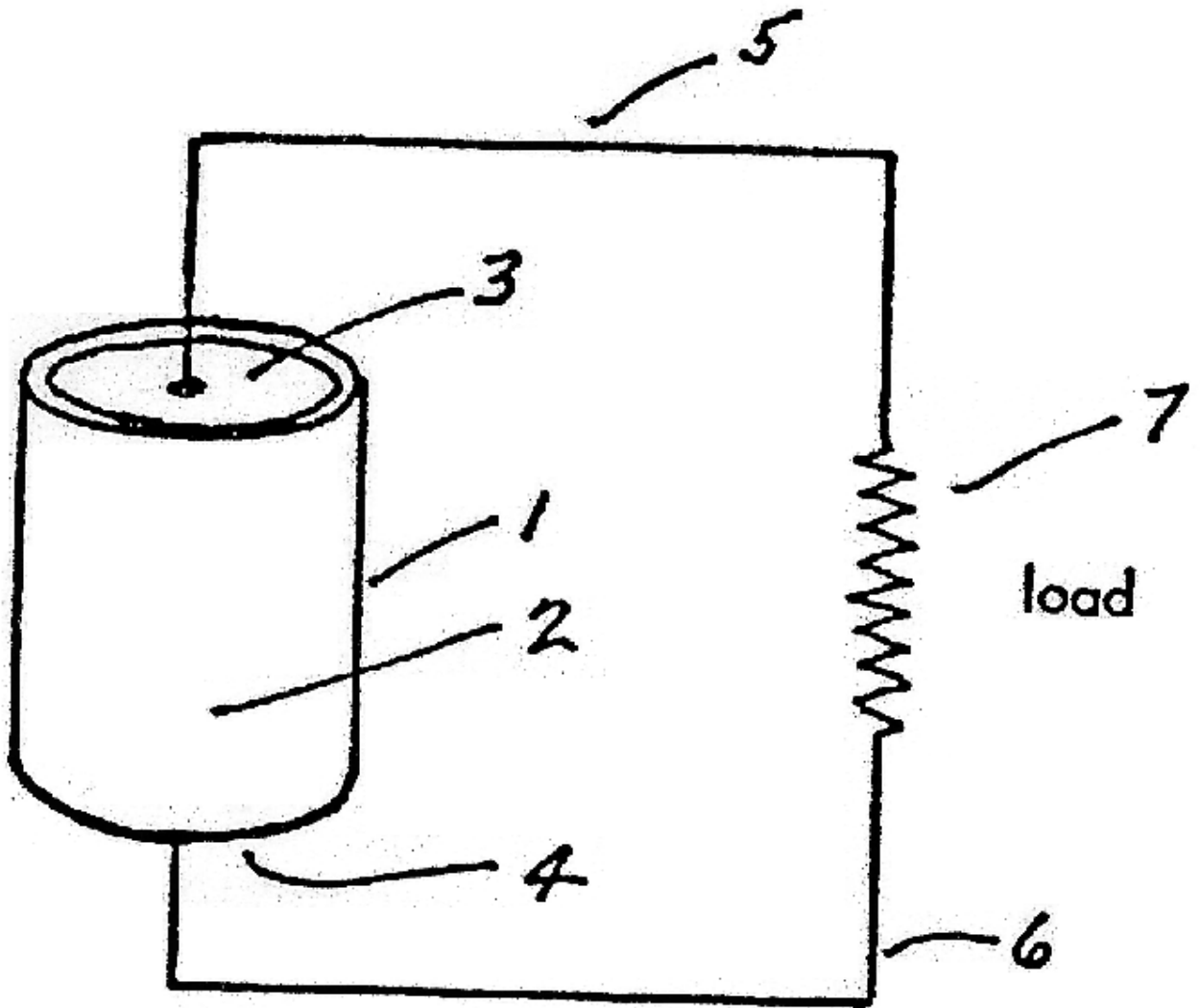

Figure 2

