

PATENT SPECIFICATION



Application Date: Aug. 15, 1927. No. 21,452/27.

300,311

Complete Accepted: Nov. 15, 1928.

COMPLETE SPECIFICATION.

A Method of and an Apparatus or Machine for Producing Force or Motion.

I, THOMAS TOWNSEND BROWN, of 15, Eighth Street, in the City of Zanesville, State of Ohio, United States of America, a citizen of the United States of America, do hereby declare the nature of this invention and in what manner the same is to be performed, to be particularly described and ascertained in and by the following statement:—

10 This invention relates to a method of controlling gravitation and for deriving power therefrom, and to a method of producing linear force or motion. The method is fundamentally electrical.

15 The invention also relates to machines or apparatus requiring electrical energy that control or influence the gravitational field or the energy of gravitation; also to machines or apparatus requiring electrical energy that exhibit a linear force or motion which is believed to be independent of all frames of reference save that which is at rest relative to the universe taken as a whole, and said linear force or motion is furthermore believed to have no equal and opposite reaction that can be observed by any method commonly known and accepted by the physical science to date.

30 The invention further relates to machines or apparatus that depend for their force action or motive power on the gravitational field or energy of gravitation that is being controlled or influenced as above stated; also, to machines or apparatus that depend for their force action or motive power on the linear force or motion exhibited by such machines or apparatus previously mentioned.

40 The invention further relates to machines and apparatus that derive usable energy or power from the gravitational field or from the energy of gravitation by suitable arrangement, using such machines and apparatus as first above stated as principal agents.

To show the universal adaptability of my novel method, said method is capable of practical performance and use in connection with motors for automobiles, space cars, ships, railway locomotion, prime movers for power installations, aeronautics. Still another field is the use

of the method and means enabling the same to function as a gravitator weight changer. Specific embodiments of the invention will be duly disclosed through the medium of the present Specification.

Referring to the accompanying drawings, forming part of this Specification: Figure 1 is an elevation, with accompanying descriptive data, broadly illustrating the characteristic or essential elements associated with any machine or apparatus in the use of which the gravitational field or the energy of gravitation is utilized and controlled, or in the use of which linear force or motion may be produced.

Figure 2 is a similar view of negative and positive electrodes with an interposed insulating member, constituting an embodiment of the invention.

Figure 3 is a similar view of a cellular gravitator composed of a plurality of cell units connected in series, capable of use in carrying the invention into practice.

Figure 4 is an elevation of positive and negative electrodes diagrammatically depicted to indicate their relation and use when conveniently placed and disposed within a vacuum tube.

Figures 5 and 5¹ are longitudinal sectional views showing my gravitator units embodied in vacuum tube form wherein heating to incandescence is permitted as by electrical resistance or induction at the negative electrode; and also permitting, where desired, the conducting of excessive heat away from the anode or positive electrode by means of air or water cooling devices.

Figure 6 is an elevation of an embodiment of my invention in a rotary or wheel type of motor utilizing the cellular gravitators illustrated in Figure 3.

Figure 7 is a view similar to Figure 6 of another wheel form or rotary type of motor involving the use of the gravitator units illustrated in Figure 5, or Figure 5¹.

Figure 8 is a perspective view partly in section of the cellular gravitator of Figure 3 illustrating the details thereof.

Figures 9, 10 and 10a are detail views of the cellular gravitator.

Figure 11 is a view similar to Figure 8

55

60

65

70

75

80

85

90

95

100

105

P
D

with the same idea incorporated in a rotary motor.

Figures 12 and 13 are detail views thereof.

5 The general showing in Figure 1 will make clear how my method for controlling or influencing the gravitational field or the energy of gravitation, or for producing linear force or motion, is utilized by
10 any machine or apparatus having the characteristics now to be pointed out.

Such a machine has two major parts A and B. These parts may be composed of any material capable of being charged electrically. Mass A and mass B may be
15 termed electrodes A and B respectively. Electrode A is charged negatively with respect to electrode B, or what is substantially the same, electrode B is charged
20 positively with respect to electrode A, or what is usually the case, electrode A has an excess of electrons while electrode B has an excess of protons.

While charged in this manner the total
25 force of A toward B is the sum of force g (due to the normal gravitational field), and force e (due to the imposed electrical field) and force x (due to the resultant of the unbalanced gravitational forces
30 caused by the electro-negative charge or by the presence of an excess of electrons on electrode A and by the electro-positive charge or by the presence of an excess of protons on electrode B).

35 Likewise the total force of B toward A is the sum of force g (due to the normal gravitational field), and force e (due to the imposed electrical field), minus force
40 x (due to the resultant of unbalanced gravitational forces caused by the electro-negative charge or by the presence of an excess of electrons on electrode A and by the electro-positive charge or by the presence
45 of an excess of protons on electrode B).

By the cancellation of similar and opposing forces and by the addition of similar and allied forces the two electrodes taken collectively possess a force $2x$ in the
50 direction of B. This force $2x$ shared by both electrodes exists as a tendency of these electrodes to move or accelerate in the direction of the force, that is, A toward B and B away from A. More-
55 over any machine or apparatus possessing electrodes A and B will exhibit such a lateral acceleration or motion if free to move. Such a motion is believed to be due to the direct control and influence
60 of the energy of gravitation by the electrical energy which exists in the unlike electrical charges present on the affected electrodes. This motion seems to possess
65 no equal or opposite motion that is detectable by the present day mechanics.

It is to be understood that in explaining the theory underlying my invention I am imparting by best understanding of that theory, derived from practical demonstration by the use of appropriate
70 apparatus made in keeping with the teachings of the present Specification. The practice of the method, and apparatus aiding in the performance of the method,
75 have been successful as herein disclosed, and the breadth of my invention and discovery is such as to embrace any corrected or more refined theory that may be found to underlie the phenomena which I believe myself to be the first to discover
80 and put to practical service.

In this Specification I have used terms as "gravitator cells" and "gravitator cellular body" which are words of my
85 own coining in making reference to the particular type of cell I employ in the present invention. Wherever the construction involves the use of a pair of electrodes, separated by an insulating
90 plate or member, such construction complies with the term gravitator cells, and when two or more gravitator cells are connected in series within a body, such will fall within the meaning of gravitator cellular body.
95

In Figure 2 the electrodes A and B are shown as having placed between them an insulating plate or member C of suitable material, such that the minimum number
100 of electrons or ions may successfully penetrate it. This constitutes a cellular gravitator consisting of one gravitator cell.

A cellular gravitator, consisting of more than one cell, will have the cell units connected in series. This type is illustrated
105 in Figure 3, D being insulating members and E suitable conducting plates. It will be readily appreciated that many different arrangements for cell units, each possessing
110 distinct advantages, may be resorted to.

One arrangement, such as just referred to, is illustrated in Figure 6 of the drawings. Here the cells designated F are
115 grouped in spaced relation and placed evenly around the circumference of a wheel G. Each group of cells F possesses a linear acceleration and the wheel rotates as a result of the combined
120 forces. It will be understood that, the cells being spaced substantial distances apart, the separation of adjacent positive and negative elements of separate cells is greater than the separation of the positive
125 and negative elements of any cell, and the materials of which the cells are formed being the more readily affected by the phenomena underlying my invention than the mere space between adjacent cells, any
130

forces existing between positive and negative elements of adjacent cells can never become of sufficient magnitude to neutralize or balance the force created by the respective cells adjoining said spaces. The uses to which such a motor, wheel, or rotor may be put are practically limitless, as can be readily understood, without further description. The structure may suitably be called a gravitator motor of cellular type.

In keeping with the purpose of my invention an apparatus may employ the electrodes A and B within a vacuum tube. This aspect of the invention is shown in Figures 4 and 5. In Figure 4 the electrodes A and B are such as are adapted to be placed within a vacuum tube H (Fig. 5), the frame and mounting being well within the province of the skilled artisan. Electrons, ions, or thermions can migrate readily from A to B. The construction may be appropriately termed an electronic, ionic, or thermionic gravitator as the case may be.

In certain of the last named types of gravitator units, it is desirable or necessary to heat to incandescence the whole or a part of electrode A to obtain better emission of negative thermions or electrons or at least to be able to control that emission by variation in the temperature of said electrode A. Since such variations also influence the magnitude of the longitudinal force or acceleration exhibited by the tube, it proves to be a very convenient method of varying this effect and of electrically controlling the motion of the tube. The electrode A may be heated to incandescence in any convenient way as by the ordinary methods utilizing electrical resistance or electrical induction, an instance of the former being shown at J (Fig. 5) and an instance of the latter at J¹ (Fig. 5¹), the vacuum tube in Fig. 5¹ being designated H¹.

Moreover in certain types of the gravitator units, now being considered, it is advantageous or necessary also to conduct away from the anode or positive electrode B excessive heat that may be generated during the operation of tube H or H¹. Such cooling is effected externally by means of air or water cooled flanges that are in thermo connection with the anode, or it is effected internally by passing a stream of water, air, or other fluid through a hollow anode made especially for that purpose. Air cooled flanges are illustrated at K (Fig. 5) and a hollow anode for the reception of a cooling liquid or fluid (as air or water) is shown at K¹ (Fig. 5¹). These electronic, ionic, or thermionic gravitator units may be grouped in any form productive of a de-

sired force action or motion. One such form is the arrangement illustrated in Figure 7 where the particular gravitator units in question are indicated at L, disposed around a wheel or rotary motor similarly to the arrangement of the gravitator motor of cellular type shown in Figure 6, the difference being that in Figure 7, the electronic, ionic, or thermionic gravitator units are utilized. This motor may appropriately be designated as a gravitator motor of the electronic, ionic, or thermionic type, respectively.

The gravitator motors of Figures 6 and 7 may be supplied with the necessary electrical energy for the operation and resultant motion thereof from sources outside and independent of the motor itself. In such instances they constitute external or independently excited motors. On the other hand the motors when capable of creating sufficient power to generate by any method whatsoever all the electrical energy required therein for the operation of said motors are distinguished by being internal or self-excited. Here, it will be understood that the energy created by the operation of the motor may at times be vastly in excess of the energy required to operate the motor. In some instances the ratio may be even as high as a million to one. Inasmuch as any suitable means for supplying the necessary electrical energy, and suitable conducting means for permitting the energy generated by the motor to exert the expected influence on the same may be readily supplied, it is now deemed necessary to illustrate details herein. In said self-excited motors the energy necessary to overcome the friction or other resistance in the physical structure of the apparatus, and even to accelerate the motors against such resistance, is believed to be derived solely from the gravitational field or the energy of gravitation. Furthermore, said acceleration in the self-excited gravitator motor can be harnessed mechanically so as to produce usable energy or power, said usable energy or power, as aforesaid, being derived from or transferred by the apparatus solely from the energy of gravitation.

The gravitator motors function as a result of the mutual and unidirectional forces exerted by their charged electrodes. The direction of these forces and the resultant motion thereby produced are usually toward the positive electrode. This movement is practically linear. It is this primary action with which I deal.

As has already been pointed out herein, there are two ways in which this primary action can accomplish mechanical work. First, by operating in a linear path as it

70

75

80

85

90

95

100

105

110

115

120

125

130

does naturally, or second, by operating in a curved path. Since the circle is the most easily applied of all the geometric figures, it follows that the rotary form is the important. While other forms may be built it has been considered necessary to explain and illustrate only the linear and rotary forms.

The linear form of cellular gravitator is illustrated in detail in Figures 8, 9 and 10. It is built up of a number of metallic plates alternated or staggered with sheets of insulating material (Fig. 3). Each pair of plates so separated by insulation act as one gravitator cell, and each plate exhibits the desired force laterally. The potential is applied on the end plates and the potential difference is divided equally among the cells. Each metallic plate in the system possesses a force usually toward the positively charged terminus, and the system as a whole moves or tends to move in that direction. It is a linear motor, and the line of its action is parallel to the line of its electrodes.

There are three general rules to follow in the construction of such motors. First, the insulating sheets should be as thin as possible and yet have a relatively high puncture voltage. It is advisable also to use paraffin-saturated insulators on account of their high specific resistance. Second, the potential difference between any two metallic plates should be as high as possible and yet be safely under the minimum puncture voltage of the insulator. Third, there should, in most cases, be as many plates as possible in order that the saturation voltage of the system might be raised well above the highest voltage limit upon which the motor is operated. Reference has previously been made to the fact that in the preferred embodiment of the invention herein disclosed the movement is towards the positive electrode. However, it will be clear that motion may be had in a reverse direction determined by what I have just termed "saturation voltage", by which is meant the efficiency peak or maximum of action for that particular type of motor; the theory, as I may describe it, being that as the voltage is increased the force or action increases to a maximum which represents the greatest action in a negative-to-positive direction. If the voltage were increased beyond that maximum the action would decrease to zero and thence to the positive-to-negative direction.

Referring more specifically to Figs. 8, 9, and 10, red fiber end plates 1 act as supports and end insulators, and the first metallic plate 2 (for example aluminium) is connected electrically, through the fiber

end plate, with the terminal 5. The second insulating sheet 3 is composed, for example, of varnished cambric sometimes known as "empire cloth". The relative size and arrangement of the metallic plate and insulating sheets are best seen in Figures 9 and 10. A paraffin filler H is placed between adjacent insulating sheets and around the edges of the metallic plates (Fig. 10a) and 6 represents a thin paraffin coating over the whole motor proper. 7 and 8 indicate successive layers of "empire cloth" or similar material, and 9 is a binding tape therefor. A thin film of a substance such as black spirit varnish 10 protects and insulates the entire outer surface. A phosphor bronze safety gap element 11 is connected electrically with the terminal (not shown) opposite to the terminal 5. A safety gap element corresponding with the element 11 is electrically connected with the terminal 5, but it has not been shown, in order better to illustrate interior parts. The purpose of the safety gaps is to limit the voltage imposed on the motor to the predetermined maximum and to prevent puncture.

The rotary motor (Figs. 11, 12 and 13), comprises broadly speaking, an assembly of a plurality of linear motors, fastened to or bent around the circumference of a wheel. In that case the wheel limits the action of the linear motors to a circle, and the wheel rotates in the manner of a fireworks pin wheel. The illustrations I have given are typical. The forms of Figures 6 and 7 have been defined. In Figure 11, the insulating end disk 1a has an opening 2a therethrough for an extension of the shaft 12. The disk 1a is secured to a suitable insulating motor shell, by fiber bolts or screws in any convenient manner, there being another of these disks at the opposite end of the shell, in the same manner as the opposite end plates 1 in Figure 8. The cells are built upon an insulating tube 11a disposed about the shaft-space 3a. Thick insulating wedges 4a separate the four linear motors illustrated. These thick insulating wedges, so-called, are substantially greater in body than the aggregate insulating sheets of the units. In some instances, however, dependent upon materials employed for the charged elements and the insulating members, this need not necessarily be the case. In each motor of this circular series of motors, there are the alternate sheets of insulation 5a associated with the alternate metallic plates 6a; paraffin fillers 7a along the edges of the plates 6a and between the insulating sheets 5a being employed similarly to the use of paraffin in Figure 8.

The rotary motor is encircled by metallic (preferably copper) collector rings 10a, which are connected with the end metallic plates of the separate linear motors at 9a and 13 (Fig. 12), one of these connections 9 being shown in detail where the insulating tube is cut away at 8 (Fig. 11).

It is unnecessary herein to illustrate a housing or bearings because any insulated housing and good ball bearings, conveniently supplied, will complete the motor. The potential is applied to the safety gap mounted on the housing and thence is conducted to the collector rings of the motor by means of sliding brushes.

While I have in the foregoing Specification outlined, in connection with the broader aspects of my invention, certain forms and details, I desire it understood that specific details have been referred to for the purpose of imparting a full and clear understanding of the invention, and not for purposes of limitation, because it should be apparent that many changes in construction and arrangement, and many embodiments of the invention, other than those illustrated, are possible without departing from the spirit of the invention or the scope of the appended claims.

Having now particularly described and ascertained the nature of my said invention and in what manner the same is to be performed, I declare that what I claim is:—

1. A method of producing force or motion, which comprises the step of aggregating the predominating gravitational lateral or linear forces of positive and negative charges which are so cooperatively related as to eliminate or practically eliminate the effect of the similar and opposing forces which said charges exert.

2. A method of producing force or motion, in which a mechanical or structural part is associated with at least two electrodes or the like, of which the adjacent electrodes or the like have charges of differing characteristics, the resultant, predominating, uni-directional gravitational force of said electrodes or the like being utilized to produce linear force or motion of said part.

3. A method according to Claim 1 or 2, in which the predominating force of the charges or electrodes is due to the normal gravitational field and the imposed electrical field.

4. A method according to Claim 1, 2 or 3, in which the electrodes or other elements bearing the charges are mounted, preferably rigidly, on a body or support adapted to move or exert force in the general direction of alignment of the electrodes or other charge-bearing elements.

5. A machine or apparatus for producing force or motion, which includes at least two electrodes or like elements adapted to be differently charged, so relatively arranged that they produce a combined linear force or motion in the general direction of their alignment.

6. A machine according to Claim 5, in which the electrodes or like elements are mounted, preferably rigidly, on a mechanical or structural part, whereby the predominating uni-directional force obtained from the electrodes or the like is adapted to move said part or to oppose forces tending to move it counter to the direction in which it would be moved by the action of the electrodes or the like.

7. A machine according to Claim 5 or 6, in which the energy necessary for charging the electrodes or the like is obtained either from the electrodes themselves or from an independent source.

8. A machine according to Claim 5, 6 or 7, whose force action or motive power depends in part on the gravitational field or energy of gravitation which is controlled or influenced by the action of the electrodes or the like.

9. A machine according to any of Claims 5 to 8, in the form of a motor including a gravitator cell or a gravitator cellular body, substantially as described.

10. A machine according to Claim 9, in which the gravitator cellular body or an assembly of the gravitator cells is mounted on a wheel-like support, whereby rotation of the latter may be effected, said cells being of electronic, ionic or thermionic type.

11. A method of controlling or influencing the gravitational field or the energy of gravitation and for deriving energy or power therefrom comprising the use of at least two masses differently electrically charged, whereby the surrounding gravitational field is affected or distorted by the imposed electrical field surrounding said charged masses, resulting in a uni-directional force being exerted on the system of charged masses in the general direction of the alignment of the masses, which system when permitted to move in response to said force in the above mentioned direction derives and accumulates as the result of said movement usable energy or power from the energy of gravitation or the gravitational field which is so controlled, influenced, or distorted.

12. The method of and the machine or apparatus for producing force or motion, by electrically controlling or influencing the gravitational field or energy of gravitation, substantially as hereinbefore described with reference to the accompanying drawings.

Dated this 15th day of August, 1927.

For the Applicant,
HERBERT HADDAN & Co.,
Chartered Patent Agents,
31 and 32, Bedford Street, Strand,
London, W.C. 2.

Redhill: Printed for His Majesty's Stationery Office, by Love & Malcomson, Ltd.—1928.

[This Drawing is a reproduction of the Original on a reduced scale.]

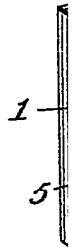
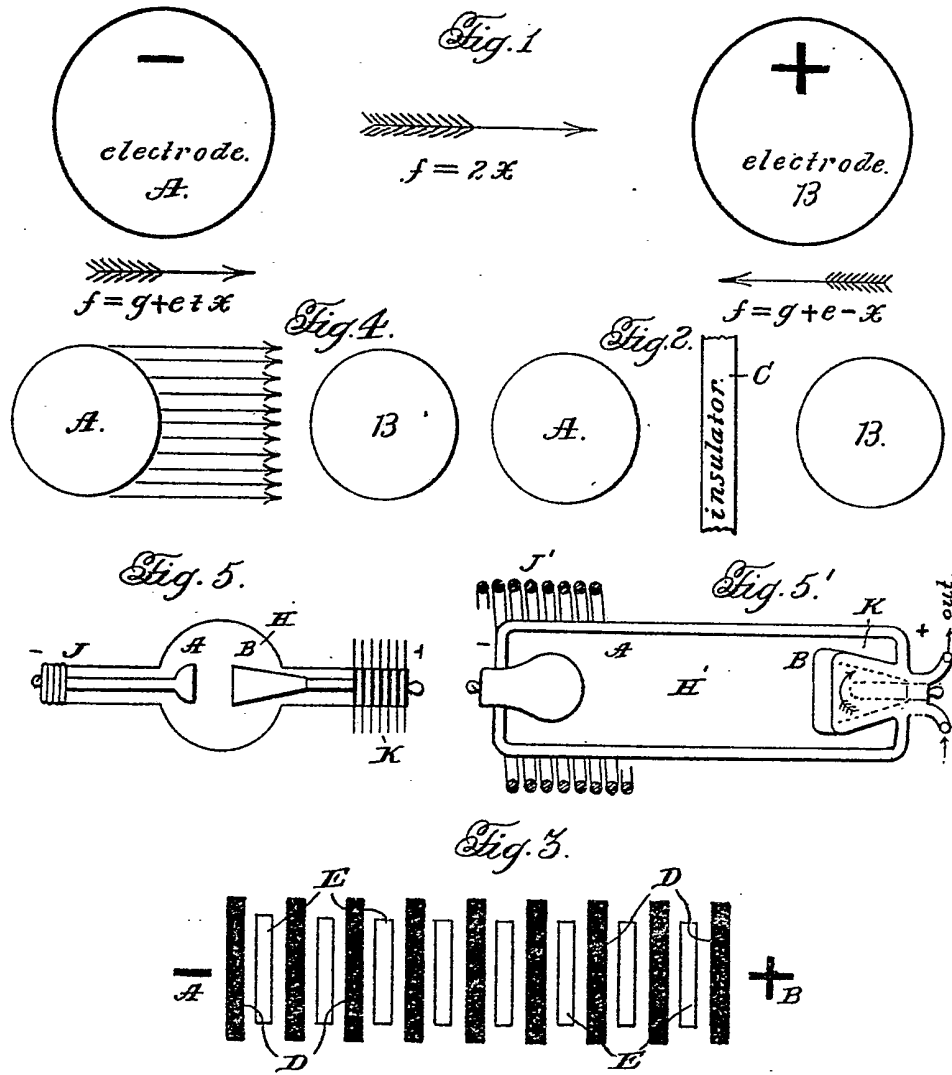

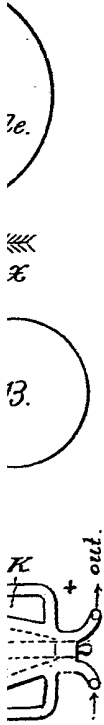
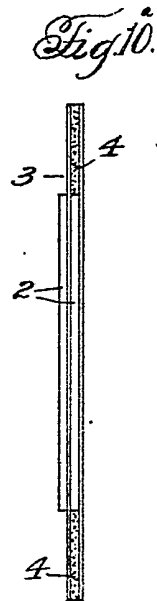
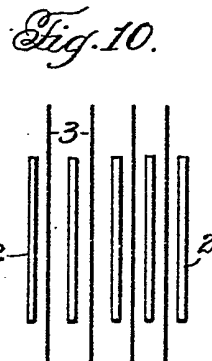
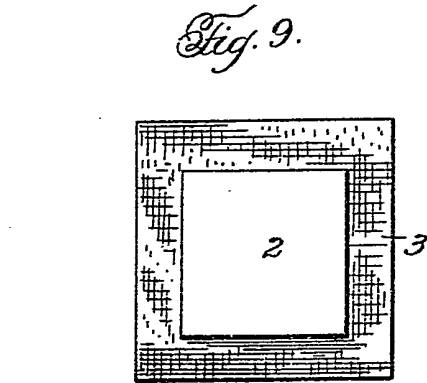
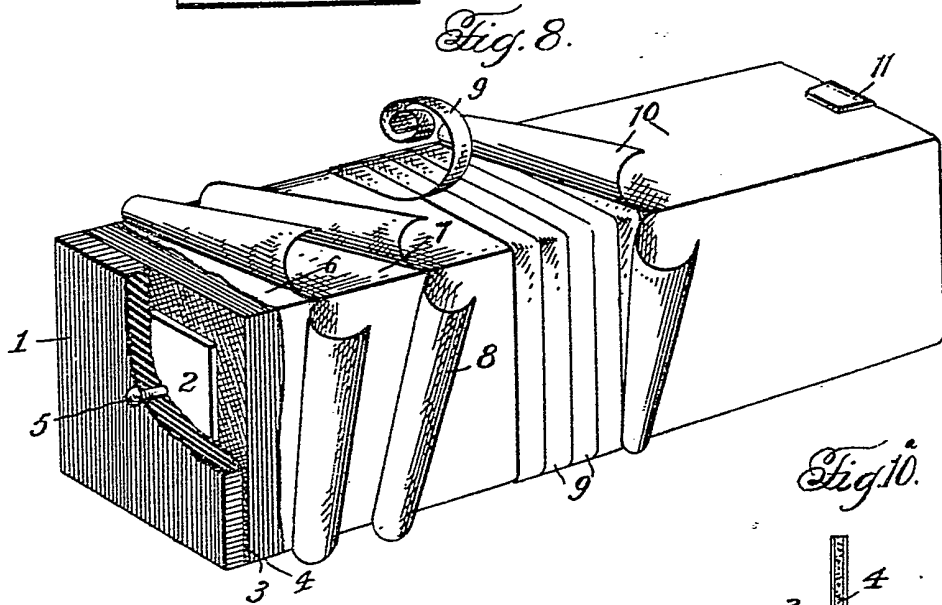
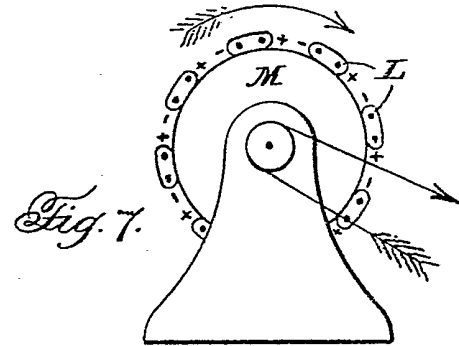
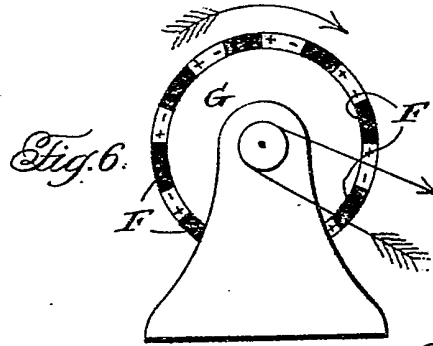

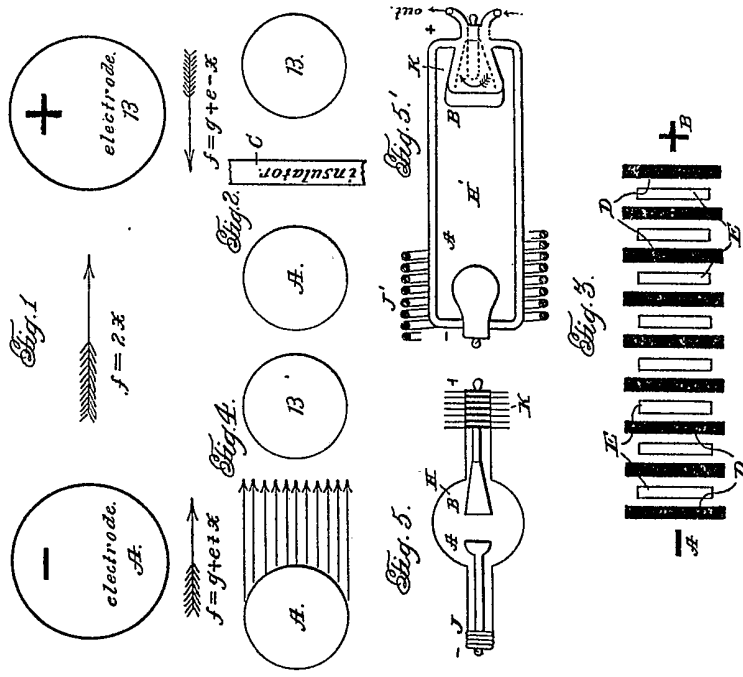

[This Drawing is a reproduction of the Original on a reduced scale]

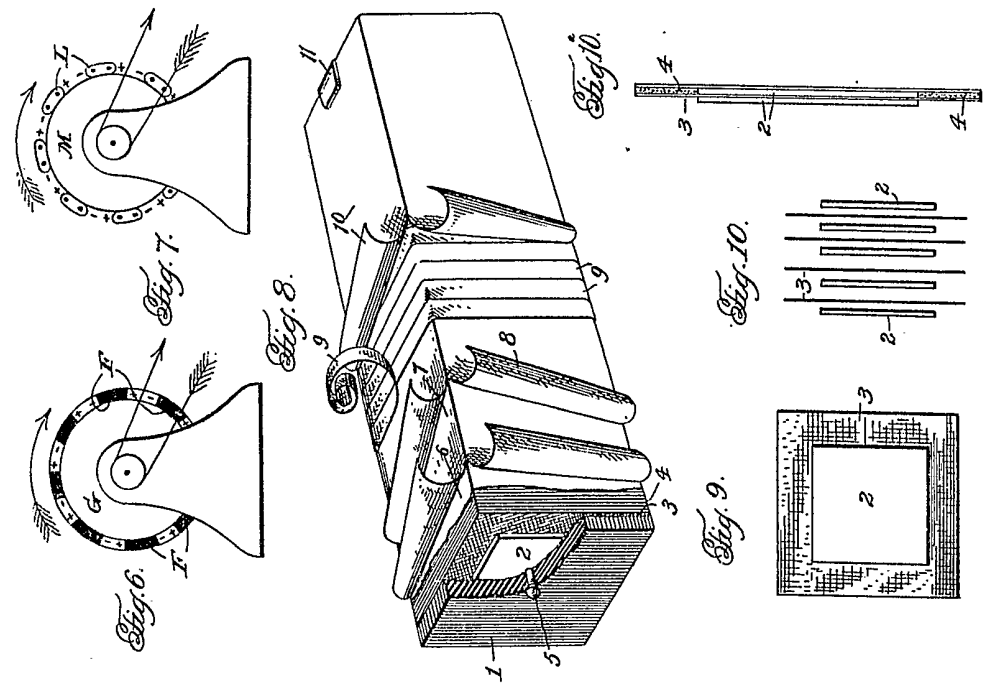

[This Drawing is a reproduction of the Original on a reduced scale.]

