

Ìàø ìûûé ñàéò



Èíîéëý ìðíàéòà "Àíòðà"

À 1990à. àðîéíé íàó-íóò ñòðóáééíá Ìíëèíáíéíáí ààéàðéííáí éííðéòóòà (ÌÀÈ) íà ðàðððéðéðé èííðéòóòà «Ìàøéíííðíàéò» à àíííòéàòéè «Àýðíðííàðàè», áúéà ñóéðéðíààà èàáððàðéðéòý ðàóíé-àíéíé ðéçðéè. Èííéàáíààéý ìðíàééèíý à íáððàééáðéè èçó-áíéý àçàèíááéíðàéý ýééèððíàáéíðóò ñéàé è ñððàáéáðéà ýóóáéðéáííðé ñúóò ìàðíáíá ìàðááá-è ýééèððíàáéíðóòé ýíáðáéè. Ðàáíóò ðéíáíéðíàáéèíý -àíðóíé èíááíðéíàé è ìðíàééè à ðáííí ñòðóáéí-àíðàà ñ ÌÀÈ ñ èàðááðà 310, ñ ó-àíðéàì Èíàáéááà È.È., ìðíàíííðà, à.ò.í., Ðúááéíáà Á.Á., ìðíàíííðà, à.ò.í., à ðàéèá Èððóéíá È.Á., áúááòà, è.ò.í.

À ìàðéíá 1990 à., à ðàçóéúòàðà áíáéèçà èàáððàðéðéòý àáííóò ñ èííéàáíààéð èèàðéíáíéèè èèððááúò ñòðóéòóð ñ ìððéòàðáéúíé àýçéíðóð [Physics of Negative Viscosity Phenomena. Prof. Victor P.Starr, Massachusetts Institute of Technology] ñýáééííý ìðááíðàééáðéà í ñòðóéòóðà èàáíðéíé ñðáú, íà óííá éíðéðéè ðéðéðóðíý ìðéáú-íúá àéý íáí ýééèððíàáéíðóòà è àðáéèðàééííúá àçàèíááéíðàéý. À ðàçóéúòàðà ýóíáí áúé ìðíàááá ðýà ýéííáðéíáíðéíá, èà-áíðàáíí ñððááðéááððéè ðáíðéð, è è íà-àéò 1991 à. àéý èàáððàðéðéè áúéí ñíðàáéáí Óàóíé-àíéíá Çàááéá íà èçáðíáéáðéà «Óíððéíðàá àéý ìðáíðàçáíáéý áíóððáííáé ýíáðáéè áúáíðàá». Ðàáí-áý óíðáííáé àúéà ñéçááá çà 2,5 áíá, è ñáðáéíá 1993 à.

Ýéííáðéíáíðéíá ìðíàééèíý ìáðíáíéáèðàéúíá àðáíý áúéíóò áí ìíáíðà çàèðúðéý èàáððàðéðéè ñáííð 1993 à. ñáýçáííáí ñ ðéíáííáúé ìðíàéáíáé èíááíðéíá è ìðéàááðááí è ñððáà ìíáúáéý èàáððàðéðéè è ðàçðóóáíéð óíðáííáéè. Èðáðéíá ñéíáéá è ðàçóéúòàðà ýéííáðéíáíðéíá ìðéáíýðíý íéæà á ìàðáé ñððáúá.

Ìáíáðéíáí ñéçàðú, -òí à ìàðéíá 1993-99 àá. ìðááíðéíáéèíý ìííðéè ìáéðé ðéíáíéðíàáéá àéý áíííçááéý èàáððàðéðéè óíðáííáéè à ðàçéè-íúò áííóááððíàáííúò ñòðóéòóðàò, íà-èíáý ìð Áéàááíéè ìáéè è çàéáí-èááý Ñíááóí ááçííáíííðé. È ñíæàéáíéð, áíéçíáí áíéíáéý ñí ñóéðíú ñóúáíðàóðúáé ìáó-íé ìíííéèè è ýóé ìðíàéáíá íá áúéí ìðýáéáí. Ñááíáíý ñ ìðíàéòó «Àíòðà» áááóíý èíáéíáðíí-áíáéèðé-àíéèà è ìàðáíóòà ðááíóò à -àíðíí ñðýáéá. À ìáíðéíáúá àðáíý èíááóíý ñéíúé èííéáéð àíéíáíðàòéè àéý èçáðíáéáðéý ýéííáðéíáíðéúíáí ñðáíáà è áííðéáíóòú áíáíáíð, ìííðé ñ íáéíðéíáé ìðááéçàééýíé ìðííèðáéúíí èçáðíáéáðéý è ìðíàáááéý ñéíé ìðíàðáíí èííéàáíáíáéé, áéð-áý è ìááééí-áéíéíáé-àíéèà àííáéòú.

Àáóéòú. (Áíáéí Ñ.Ì. è Ðíúèí Á.Á.)

ààéáá ý ìðéèáááð ðàéè ñí ñððáíéòú http://www.watchersnet.com/nightwatch/antigrav_paper.html

Experimental Research of the Magnetic-Gravity Effects

V. V. Roschin, E-mail: rochtchin@mail.ru
S. M. Godin, E-mail: serjio@glasnet.ru

Institute for High Temperatures, Russian Academy of Science, Izhorskaya
13/19, Moscow 127412, Russia

Abstract

In the present paper the results of the experimental research of Magnetic-Gravity Effects are presented. The abnormal magnetic and thermal changes in the radius of 15 meters from the researched device were measured as well. PACS: 41.20.-q; 44.60.+k; 76.50.+q

1. Introduction

There has been a great interest in examining nonlinear effects in the system of rotating magnetic fields. Such effects have been observed in the device called Searl's generator or SEG (SEG, Searl Effect Generator) [1-4]. An SEG consists of a series of three rings and rollers that go around those rings. All parts of SEG are based on the Law of the Squares. The rollers revolve around the plates that form the rings, but they do not touch them. There's a primary north and south pole on the rollers and a primary north and south pole on the plates. Obviously you will have the north pole of the roller attracted to the south pole of the plate. The plate and the rollers have layered structure. The external layer - Titan, then Iron, Nylon and last internal layer was made from Neodymium. John R.R. Searl has supposed that the electrons are given off from the central element (which is neodymium), and they travel out through other elements. If nylon had not been put there, the SEG would act like a laser and one pulse would go out and it would stop, build up, and another pulse would go out. But, with the nylon being, nylon acts as a control gate, and that control gate gives you an even flow of electrons throughout the SEG [4]. In [4] it was shown that in the process of magnetization of the plate and rollers, the combination of constant and variable magnetic fields for creating a special wave (sine wave) pattern on a plate surface and rollers surface was used. The basic effects are the rollers selfrunning around a ring plate and reduction of weight up to occurrence of propulsion and flying up of all magnetic system. These effects come about because of a special geometry of experimental setup. It was shown that the work of the device in critical regime is accompanied by biological and real physical phenomena. Unfortunately except for the listed references we could not find other information where similar effects are mentioned. In this paper we present the experimental device the results we have obtained.

2. The description of the experimental installation

The basic difficulty is in a choosing the materials and maintaining the necessary pattern imprinting on the plate and rollers surfaces. To simplify the technology we decided to use a one-ring design with one-ring plate (stator) and one-ring of rollers (rotor). It is obvious, that it was necessary to strengthen the rollers on a rotor by the bearings and balance the rollers well. In the suggested design the air bearings were used which provided the minimum losses due to friction. From the available description [1-4] it was not clear how it is possible to make and magnetize the stator with a diameter of about one meter. In order to make the stator from separate magnetized segments executed on the basis of

rare earth magnets with the residual induction 1 T; the segments were magnetized in a usual way by discharging capacitor battery through the coil. Afterwards the segments were assembled and glued together in a special iron armature, which reduced magnetic energy. To manufacture the stator 110 KGs of rare earth magnets were used, and to manufacture the rotor 115 KGs of that material was used. High-frequency field under magnetization was not applied. It was decided to replace an imprinting technology described in [1-4] with cross-magnetic inserts having a flux vector directed at 90 degrees to a vector of basic magnetization of a stator and rollers of a rotor. For these cross inserts the modified rare earth magnets with a residual magnetization of 1,2 T and coercive force a little bit greater than in a base material was used. In Fig.1 and Fig.2 the joint arrangement of stator 1, elements of a rotor - rollers 2 and a way of their mutual gearing by means of cross magnetic inserts 19, are shown. Between the stator and roller surfaces the air gap d of 1-mm is left.

No layered structure was used except a continuous copper foil of 0.8 mm thickness which wrapped up the stator and rollers. This foil has the direct electrical contact to magnets of a stator and rollers. Distance between inserts in the rollers is equal to distance between inserts on the stator.

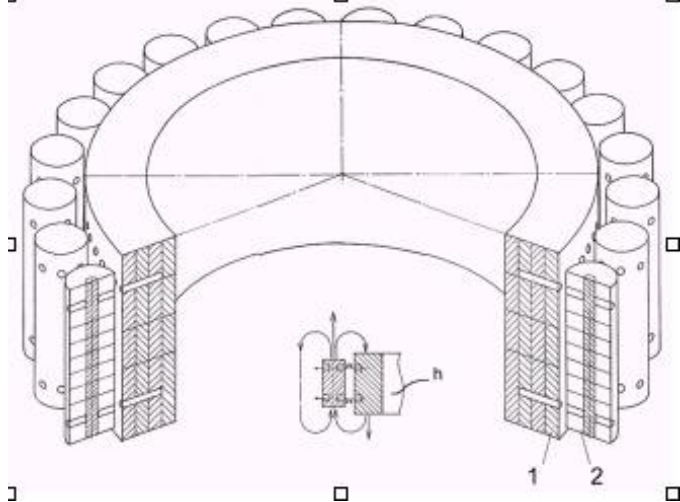

Fig.1. Variant of one-ring converter.

The ratio of parameters of the stator 1 and the rotor 2 in Fig.2 is chosen so that the relation of stator diameter - D and roller diameter - d is an integer equal to or greater than 12. Choosing such ratio allow us to achieve a magnetic spin wave resonant mode between elements of a working body of the device is achieved.

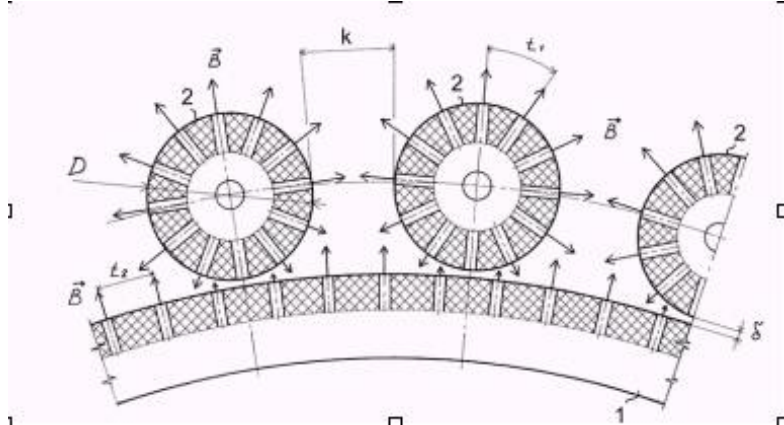

Fig.2. A way of organization of magnetic gearing stator and rollers.

The elements of magnetic system were assembled in a uniform design on the aluminium platform. In Fig.3 the general view of the platform with one-ring converter is displayed. This platform was supplied with springs, amortizers and had a possibility of moving vertical on three supports. The value of displacement was measured by the induction meter of displacement 14; thus the change of the platform weight at once has been defined during the experiment in real time. Gross weight of the platform with magnetic system in the initial condition was 350 KGs.

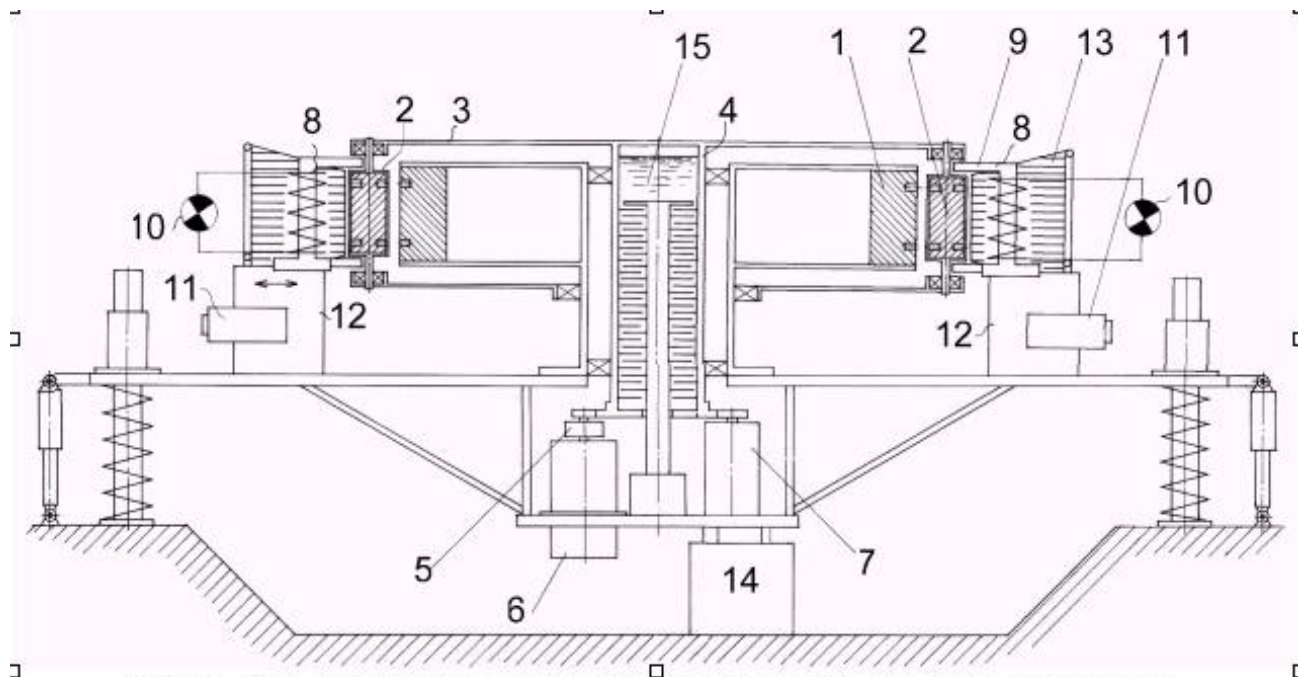

Fig.3. The general view of the platform with one-ring converter.

Fig.3. The general view of the platform with one-ring converter.

The stator 1 was mounted motionlessly, and the rollers 2 were assembled on a mobile common separator 3, connected with the basic shaft 4 of the device. Through this shaft the rotary moment was transferred. The basic shaft by the means of friction muff 5 was connected to the electrodynamic generator 7 and starting engine 6, which accelerated the converter up to a mode of self-sustained rotation. Along a rotor the electromagnetic inductors 8 with open cores 9 were located. The magnetic rollers 2 crossed the open cores of inductors 8, and closed the magnetic flux through electromagnetic inductors 8, and induced emf in them, which acted directly on an active load 10 (a set of incandescent lamps with total power 1 kW). The electromagnetic inductors 8 were equipped with an electrical drive 11 and had an opportunity to smoothly move on supports 12. To study the influence of the external high voltage on the characteristics of the converter the system of radial electrical polarization was mounted. On periphery of the rotor ring electrodes 13 were set between the electromagnetic inductors 8 having with the rollers 2 air gap of 10 mm. The electrodes are connected to a high-voltage source; the positive potential was connected to the stator, and the negative to the polarization electrodes. The voltage was adjusted in a range of 0-20 kV. In experiments the constant value of 20 kV was used. In case of emergency braking, friction disk from the ordinary car braking system was mounted on a basic shaft of the rotor. The electrodynamic generator 7 was connected to active load through a set of switches ensuring step connection of the load from 1 kW to 10 kW. The converter under going testing had in its inner structure the oil friction generator of thermal energy 15, intended for taping a superfluous power (more than 10 kW) into the thermo-exchange contour. But since the real output power of the converter in experiment has not exceeded 7 kW, the oil friction thermal generator was not used. The complete stabilization of revolutions of the rotor was carried out by electromagnetic inductors connected to an additional load, which was set of incandescent lamps with total power 1 kW.

3. Experimental results

The magnetic-gravity converter was built in a laboratory room on three concrete supports at a ground level. The ceiling height the lab room was 3 meters. Besides the presence of the iron-concrete ceiling, in immediate proximity from the magnetic system there was a generator and electric motor, which contained some tens KGs of iron and could potentially deform the field's pattern. The device was started by the electric motor, which accelerated the rotation of the rotor. The revolutions were smoothly increased up to the moment the ammeter included in a circuit of the electric motor started to show zero or lower value of a consumed current or even a presence of the back current. The presence of the back current is detected at approx. 550 rpm. The magnetic moving sensor 14 starts to detect the change in weight of the whole installation at 200 rpm. Afterwards the electric motor is completely disconnected by the electromagnetic muff and the ordinary electrodynamic generator is connected to the basic shaft of the device through the same muff. The rotor of the converter continues to self-accelerate and with the approach to the critical mode of 550 rpm, the weight of the device quickly changes. In addition to the change speed of rotation the weight depend of the power, removed into active load, (the set of ten ordinary electrical water heaters of 1 kW was used) and of the applied polarizing voltage, as well. At the maximum output power equal to 6-7 kW the change of weight G of the whole platform (total weight is about 350 KGs), reaches 35 % of the weight in an initial condition $G?$. A load of more than 7 kW results in a gradual decrease of revolutions and exit from the mode of self-generation with the subsequent complete stop of the rotor. The weight of a platform can be controlled by applying of a high voltage to cellular ring electrodes located at a distance of 10 mm from external surfaces of the rollers. Under the high 20 kV voltage (electrodes negative pole) the increase of taped power in circuit of the basic generator more than 6 kW does not influence G while the revolutions per min is not decreased to 400 rpm. "Tightening" of this effect is observed as well as the effect of hysteresis on G (a kind of "residual induction"). The experimental diagrams given on Fig.4 illustrate the modes of the converter operations.

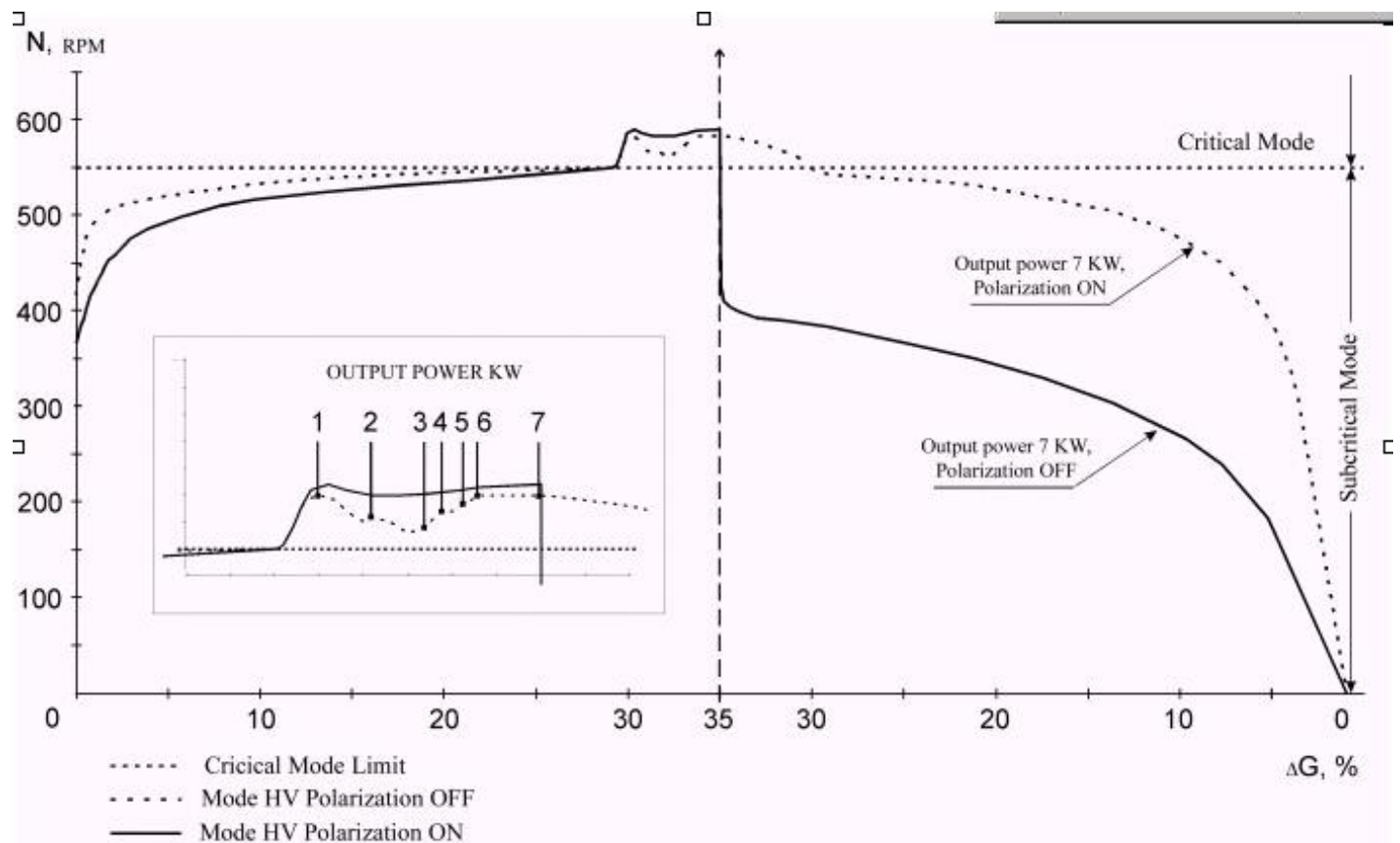

Fig. 4. Modes of operations of the magnet-gravity converter.

Fig. 4. Modes of operations of the magnet-gravity converter.

The effect of a local change of the platform weight is convertible relative to the direction of rotor turning, and has the same hysteresis. At clockwise rotation the critical mode comes in the area of 550 rpm and the propulsion force against the direction of gravitation vector is created, by analogy, at counter-clockwise rotation the critical mode comes in the area of 600 rpm and the propulsion on the direction of gravitation vector is created. The difference in approach to a critical mode of 50 - 60 rpm was observed. It is necessary to mention that the most interesting region lies above the critical area of 550 rpm, but due to a number of circumstances the implementation of such research was not possible. Other interesting effects include the work of the converter in the dark room when corona discharges are observed around the converter's rotor as a blue-pink glowing luminescence and a characteristic ozone smell. The cloud of ionization covers the area of a stator and a rotor and has accordingly toroidal form. On the background of luminescence glowing on rollers' surfaces we distinguished wave picture. A number of more vigorous strips of discharges around the rollers were observed. These discharges were of the white - yellow colour is, but the characteristic for the arc discharges sound was not audible. One more effect previously not mentioned was observed i.e. the vertical magnetic "walls" around the installation. We noticed and measured the abnormal permanent magnetic field around the converter in the radius of 15 meters. The zones of an increased intensity of a magnetic flux 0,05T located concentrically from the centre of the installation were detected. The direction of magnetic field vector in these walls coincided with the direction of rollers' field vector. The structure of these zones reminded circles on water from the thrown stone. Between these zones a portable magnetometer, which used the Hall's sensor as a sensitive element, did not register abnormal magnetic fields. The layers of an increased intensity are distributed practically without losses up to a distance of about 15 meters from the centre of the converter and quickly decrease at the border of this zone. The thickness of each layer is about 5 - 8 cm. The border of each layer has sharp shape, the distance between layers is about 50 - 60 cm and it slightly accrues when moving from the centre of the converter. The steady picture of this field was observed as well at a height of 6 m above the installation (on the second floor above the lab.). Above the second floor the measurements were not carried out. The abnormal fall of the temperature in direct affinity from the converter was also found. While the common temperature background in laboratory was + 22° (?) the fall of temperature equal to 6-8° was noticed. The same phenomenon was observed in vertical magnetic walls as well as. The measurements of temperature inside the magnetic walls were carried out by the ordinary alcohol thermometer with inertia of indication about 1,5 min. In the magnetic walls the temperature changes can be distinctly observed even by hand. The hand when placed into this magnetic wall feels real cold at once. The similar picture was observed at the height above installation, i.e. on the second floor of the laboratory as well as despite the ferro-concrete blocking of ceiling.

4. Discussion

All the results we obtained are extremely unusual and require some theoretical explanation. Unfortunately the interpretation of results within the framework of the conventional physical theory cannot explain all the observed phenomena and first of all the change of weight. The change of weight is possible to interpret as a local change of gravity force or as an occurrence of propulsion force by repelling from its own field.

Direct experiment, confirming a presence of draft force was not performed, but in any case both interpretations of the weight change do not correspond to the modern physical paradigm and demand reconsideration of the standard theory of gravitation or criticism of the second law of Newton, both of which are only possible if we take into consideration the now-advert physical media ether as understood by Faraday-Maxwell-Mie. From the modern physics position electrization and luminescence of the converter's magnetic system in the near zone is not completely clear. The phenomenon of the magnetic and thermal "walls" may be connected with Alphen's magnetic-sound waves raised in near zone in magnetized plasma induced by a variable magnetic field of a rotating rotor [5].

At present time we can not give an exact description of the interactions mechanism with environment and transformation of energy, but it is

completely obvious, that without the use of the concept of physical media - the ether in a sense of Faraday-Maxwell-Mie we are completely unable to give physically substantial theory of these phenomena. In conclusion, we emphasize that the issues of the biological influence effects and especially of the variations of real time stream effects, which must be taking place in an operative zone of the converter, were not considered at all. These issues are extremely important and absolutely unexplored; though there are some mentions of J.R.R.Searl about healing action of the SEG's radiation. Our own experience allows to make only cautious assumption that the short-term stay (dozen minutes) in a working zone of the converter with the fixed output power of 6 kW remains for the people without observed consequences. The present paper is only a beginning.

References

- 1. Von Herbert Schneider, Dr. J.B. Koeppl, Hans - Joachim Ehlers. Begegnung mit John R.R. Searl. Raum und Ziet, #39, 1989, pp. 75-80.
- 2. Von S. Gunnar Sandberg. Was ist dran am Searl-effect. Raum und Ziet, #40, 1989, pp. 67-75.
- 3. Von Herbert Schneider. Harry Watt. Dem Searl-effect auf der spur. Raum und Ziet, # 42, 1989, pp.75-81; #43, pp.73-77.
- 4. John A. Thomas Jr. ANTI-GRAVITY: The Dream Made Reality. Extraordinary Science, vol.VI, Issue2, 1994.
- 5. L.D.Landau, E.M.Lifshits. Electrodynamics of continuous media.- Moscow, Nauka, 1982. (in Russian).

Ὁδὴ ἐπὶ τῆς ἀνακάλυψης τῆς ἀποκρίσεως: Ἰὴν ἰατρίαν ἢ ἰατροῦ ἰδιοφάνει δααίτου πνεύματι Ἄνιμα ἐ ἐπιφάνει: ἐὰν ἰδεῖται ἀποκρίσει ἐ δαεῖα ἀδραστεῖ ἐννεῖα ἀποκρίσει ἐ δααίτου, ἐὰν ἰδῆται πνεύμα (ἀεὶοῦ) ἰατρίαν δααίτου ἀποκρίσει ἐὰν πνεύμα ἢ ἰδιοφάνει ἀποκρίσει ἀποκρίσει. Ἰδιοφάνει (ἰατροῦ ἀποκρίσει) ἀποκρίσει οὗτε-ἄνευ ἰατροῦ-ἀποκρίσει ἐὰν ἰατροῦ ἀποκρίσει ἐ γίνοσθαι ἰατροῦ ἀποκρίσει "δααίτου-δααίτη". Ἰδιοφάνει, ἰδιοφάνει ἀποκρίσει ἀποκρίσει - δααίτη ἰατροῦ ἀποκρίσει ἀ δααίτο, -δὲ ἀποκρίσει ἐφάνει δααίτη ἀποκρίσει, ἢ ἰδιοφάνει ἰατροῦ ἀποκρίσει. Ἄνευ ἐ δαεῖα πνεύμα ἀποκρίσει ἀποκρίσει. Ἄνευ, γίνοσθαι ἰδιοφάνει ἐ ἰατροῦ ἀποκρίσει πνεύμα δαεῖα ἀποκρίσει πνεύμα ἀποκρίσει.

Ἰατροῦ ἀποκρίσει ἰατροῦ ἀποκρίσει, ἰατροῦ ἀποκρίσει ἰατροῦ ἀποκρίσει ἰατροῦ ἀποκρίσει ἰατροῦ ἀποκρίσει ἰατροῦ ἀποκρίσει.

Ἄνευ-ἄνευ ἰατροῦ ἀποκρίσει ἐφάνει δααίτη πνεύμα οὗτε γίνοσθαι, ἰατροῦ ἀποκρίσει ἀποκρίσει ἰατροῦ ἀποκρίσει ἰατροῦ ἀποκρίσει (ἰατροῦ ἀποκρίσει ἀποκρίσει), δαεῖα ἀποκρίσει ἰατροῦ ἀποκρίσει ἰατροῦ ἀποκρίσει ἰατροῦ ἀποκρίσει ἀποκρίσει, ἢ ἰατροῦ ἀποκρίσει, ἢ ἰατροῦ ἀποκρίσει.

Ἄ 1998 ἐ 2000 ἢ ἰατροῦ ἀποκρίσει ἰατροῦ ἀποκρίσει ἰατροῦ ἀποκρίσει 81-468-759456) ἐ δαεῖα ἀποκρίσει ἰατροῦ ἀποκρίσει ἰατροῦ ἀποκρίσει, ἰατροῦ ἀποκρίσει ἢ ἰατροῦ ἀποκρίσει. Ἄνευ ἢ ἰατροῦ ἀποκρίσει, δαεῖα ἀποκρίσει "ἀποκρίσει" ἐ "δααίτη" δααίτη ἀποκρίσει ἰατροῦ ἀποκρίσει.

Ἄ ἐφάνει ἢ 1910 ἰατροῦ ἀποκρίσει ἰατροῦ ἀποκρίσει ἰατροῦ ἀποκρίσει ἰατροῦ ἀποκρίσει. Δααίτη ἀποκρίσει ἰατροῦ ἀποκρίσει ἰατροῦ ἀποκρίσει ἰατροῦ ἀποκρίσει <http://alexfrolov.narod.ru>

Alexander V. Frolov

Ἄνευ ἰατροῦ ἀποκρίσει - Our new web site

